

AD21P Acoustic Leak Detector



The HIKMICRO Acoustic Leak Detector AD21P is a high-performance device equipped with the advanced SuperDetect feature, designed to help technicians and plumbers quickly locate leaks in plumbing systems, water services, and residential or commercial properties. With four selectable digital bandpass filters, it filters and amplifies sound frequencies to ensure precise leak detection. Paired with its handheld and pick-up sensors, the AD21P can identify even the most easily overlooked leaks, helping to minimize resource waste and prevent property damage.

▪ Key Features

- Supports SuperDetect, quickly locate leak points
- Supports four ranges of selectable digital bandpass filters
- Frequency Range 150 Hz - 7500 Hz
- 1024 × 600 Resolution, 7"LCD Touch Screen
- Up to 11 hours continuous running

▪ Specification

Acoustic	
Frequency Range	150 ~ 7500 Hz
Band Pass Filters	Indoor low frequency 150 Hz to 3000 Hz Indoor mid-frequency 3000 Hz to 6000 Hz Indoor high frequency 4500 Hz to 7500 Hz Indoor all-pass 150 Hz to 7500 Hz
Amplification	Manual
SuperDetect	Yes
Image Display	
Display	1024 × 600 Resolution, 7"LCD Touch Screen
Screen Brightness	Manual /Auto
Data Storage and Communication	
Storage Media	Built-in EMMC (4GB)
Image Storage Capacity	Approx. 60,000 Images, viewable only on PC
Audio Storage Capacity	Approx. 10 hours, viewable only on PC
Audio File Format	.wav
Image Format	JPEG
General	
USB Interface	USB 2.0,USB Type-C
EMC	EN55032:2015+A11:2020 EN50130-4:2011+A1:2014 EN61000-3-3:2013
Working Temperature Range	-10 °C to 50 °C (14 °F to 122 °F)
Drop Test Height	1.2 m (3.93 ft)
Weight	Main Unit: 781 g (1.72 lb) Hand held sensor: 249 g (0.54 lb) Pick-up sensor: 488 g (1.08 lb) Headset: 214 g (0.47 lb) Standard package: 3000 g (6.61 lb)
Storage Temperature Range	-40 °C to 70 °C (-40 °F to 158 °F)
Relative Humidity	< 90 % non-condensing
Battery Type	3.6V ~ 3.635V, Rechargeable Li-ion Battery
Battery Operating Time	11 h
Battery Charging Time	4 h
Protection Level	Main Unit: IP40; Hand held sensor: IP54; Pick-up sensor: IP66;

▪ Available Model

HM-AP21-AD21P

▪ Dimension

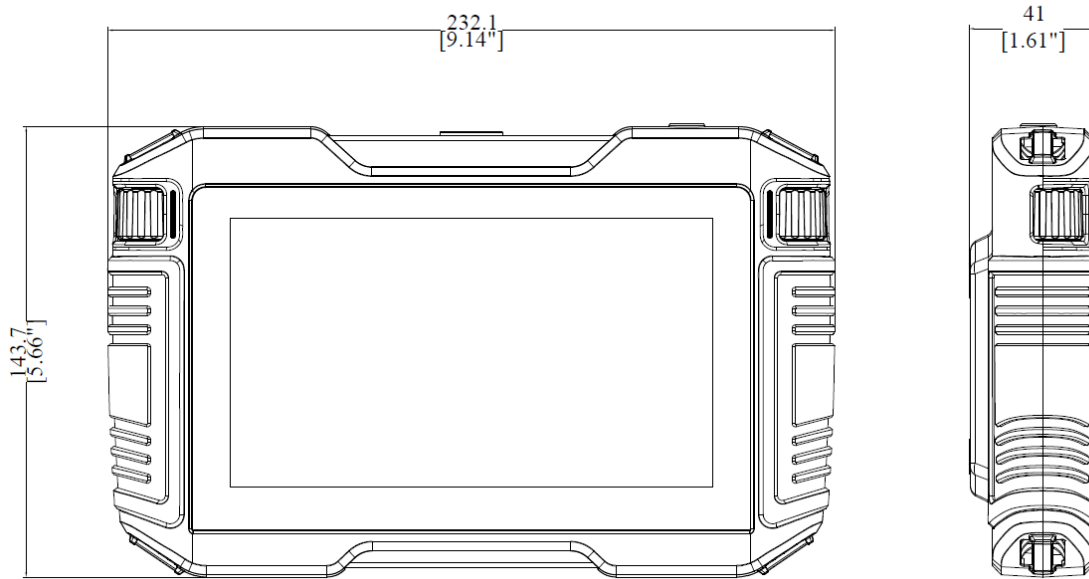

•Packaging List

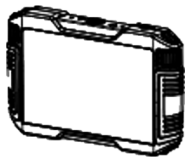

Main Body (×1)



Handheld Sensor (×1)

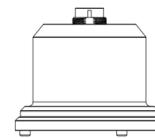

Pick-up Sensor (×1)



Handle Grip (×1)



Power Adapter (×1)



Listening Stick (×1)



Sensor Connection Cable (×1)



Quick Start Guide (×1)



Headset (×1)



USB Cable (×1)



Neck Strap (×1)



Bag (×1)



Bag Strap (×1)



 Hikmicro Industrial

 hikmicro_industrial

 HIKMICRO Industrial

 HIKMICRO

 info@hikmicrotech.com

 www.hikmicrotech.com

© Hangzhou Microimage Software Co., Ltd. All Rights Reserved.

*Note: Specifications are subject to change without notice. For the current specs,
please go to www.hikmicrotech.com